

POWER / MANUAL REWIND REELS
NORDIC SERIES 5900
3" or 4" Fluid Path for 2" through 4" I.D. Hose

REWIND: Gear-drive crank rewind or chain and sprocket drive powered by A.C. or D.C. electric motor, compressed air motor or hydraulic motor.

INLET: 3" straight victaulic is standard. 90° victaulic swivel joint available at extra cost.

GOOSENECK: 3" female NPT. Other sizes and/or threads can be furnished and must be specified.

Product temperatures from -60° to +174°F and standard pressures to 300 p.s.i. Other temperatures or pressures can be furnished at extra cost. Consult manufacturer.

NOTE: 4" x 90° victaulic inlet, 4" female NPT gooseneck and 24" diameter drum are standard on 4" reels.



Series 5900

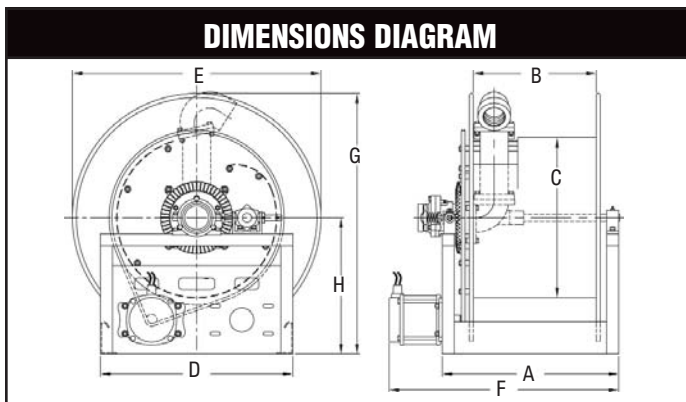

The standard color for this series is red or gray. ADD 12" to E dimension when crank is in rewind position.

Note: Weights shown in chart are for crank rewind models.	Prefix	Type	LB / KG
	EP	Electric	42 / 19
Add these amounts and model number prefix for power rewind models.	A	Air	26 / 12
	H	Hyd	26 / 12

HOSE I.D.		2	2 1/2	3	4	SPECIFICATIONS - HOSE CAPACITY AND REEL DIMENSIONS															
HOSE O.D.		2 9/16	3 3/16	3 3/4	4 3/4	EST. WEIGHT		A	B	C	D	E CRK	E ELC	E AIR	E HYD	F CRK	F ELC	F AIR	F HYD	G	H
in	mm	51	64	76	102	140 LB	in	22	16	20	24	31	31	31	31	26	29	26	28	32 1/2	17
mm		51	64	76	102	41 KG	mm	559	406	508	610	787	787	787	787	660	737	660	711	826	432
in	mm	26	9	8		150 LB	in	30	24	20	24	31	31	31	31	34	37	34	36	32 1/2	17
mm		26	9	8		42 KG	mm	762	610	508	610	787	787	787	787	864	940	864	914	826	432
in	mm	37	14	11		160 LB	in	38	32	20	24	31	31	31	31	42	45	42	44	32 1/2	17
mm		37	14	11		39 KG	mm	965	813	508	610	787	787	787	787	1067	1143	1067	1118	826	432
in	mm	18	9	9		146 LB	in	18	12	20	24	36	36	36	36	22	25	22	24	39	21
mm		18	9	9		42 KG	mm	457	305	508	610	914	914	914	914	559	635	559	610	991	533
in	mm	27	15	12	4	150 LB	in	22	16	20	24	36	36	36	36	26	29	26	28	39	21
mm		27	15	12	4	43 KG	mm	559	406	508	610	914	914	914	914	660	737	660	711	991	533
in	mm	27	15	11	5	180 LB	in	18	12	20	24	39	39	39	39	22	25	22	24	40 1/2	21
mm		27	15	11	5	45 KG	mm	457	305	508	610	991	991	991	991	559	635	559	610	1029	533
in	mm	41	24	15	5	200 LB	in	22	16	20	24	39	39	39	39	26	29	26	28	40 1/2	21
mm		41	24	15	5	47 KG	mm	559	406	508	610	991	991	991	991	660	737	660	711	1029	533
in	mm	61	37	20	8	210 LB	in	30	24	20	24	39	39	39	39	34	37	34	36	40 1/2	21
mm		61	37	20	8	50 KG	mm	762	610	508	610	991	991	991	991	864	940	864	914	1029	533

Refer to page 31 to build a complete model number.

USA: **800-444-3134** Europe: **+44 (0) 1536 406999**
Canada: **800-268-1756** Asia: **63-45-599-3721**

www.reelcraft.com

Models listed with an icon can be shipped same day upon request when the order is received by 11:30 AM local time for quantities of 5 or fewer.

Indiana Warehouse California Warehouse
 Indiana & California Warehouses Canadian Warehouse