



LARGE FRAME REELS

NORDIC Series 3100 / 4800

SPRING DRIVEN REELS

NORDIC SERIES 3100 / 4800

1/2", 3/4" or 1 1/2" Fluid Path for 1/4" through 1 1/2" I.D. Hose

Series 4800

INLET: 1/2" up to 1" female/male NPT 90° swivel joint.

GOOSENECK: 1/2" up to 1" female/male NPT.

Series 4830 reels handle hose from 1/2" through 1" I.D. Inlet is 1/2" up to 1" female/male NPT 90° swivel joint. Gooseneck is 1/2" up to 1" female/male NPT. **Series 4800** reels handle hose from 1" through 1 1/2" I.D. 2" straight victaulic is standard. 1 1/2" male or female NPT straight swivel joint may be specified at no extra cost. Gooseneck is 1" to 1 1/2" female/male NPT.

Series 3100 reels handle hose from 1/4" through 1" I.D.

ROLLER POSITION: You must specify roller position BW, SW or TW. If roller position is not specified, reels will be shipped with rollers in POSITION BW. See page 14.

HOSE STOP: A hose stop should be used to prevent damage to rollers and nozzles and to permit adjustment of free hose length. See description on page 54. Hose stops are available at extra cost.

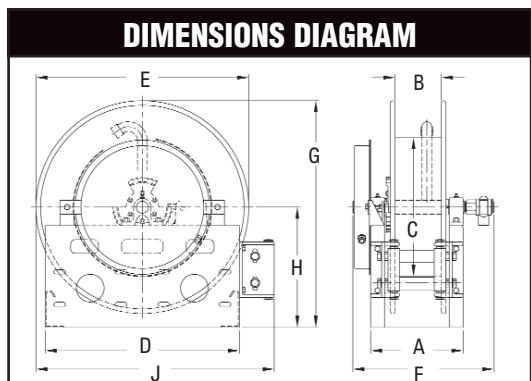

Series 3100 / 4830 product temperatures from -60° to +174° F and standard pressures to 1000 p.s.i. **Series 4800** product temperatures from -80° to + 450°F at standard pressures to 300 p.s.i.

Reels to operate at other temperatures or pressures can be furnished at extra cost. Consult manufacturer.

NOTE: Other sizes and/or threads can be furnished for gooseneck when specified. Series 3101 reels use a stronger spring assembly for heavy duty applications.

See numbering system on page 31 for complete part numbers. Standard color is red or gray.

HOSE I.D.		in	1/4	3/8	1/2	3/4	1	1 1/4	1 1/2	SPECIFICATIONS - HOSE CAPACITY AND REEL DIMENSIONS										
HOSE O.D.		mm	6	10	13	19	25	32	38	*20" (508mm) dia drum on Model#4830-31-10 for 1/2" and 3/4" hose										
		in	5/8	3/4	7/8	1 9/32	1 9/16	1 13/16	2 1/16											
		mm	16	19	22	33	40	46	52											
MODEL	HOSE LENGTH									Est. Weight	A	B	C	D	E	F	G	H	J	
3100-19-4	ft	40	40	30						85 LB	in	9	4	11 1/4	21	19	15	22 1/2	13	25
	m	12	12	9						39 KG	mm	229	102	286	533	483	381	572	330	635
3100-23-4	ft	50	50	50						88 LB	in	9	4	15	21	23	15	24 1/2	13	26
	m	15	15	15						40 KG	mm	229	102	381	533	584	381	622	330	660
3100-23-5	ft	75	75	60						89 LB	in	10	5	15	21	23	16	24 1/2	13	26
	m	23	23	18						40 KG	mm	254	127	381	533	584	406	622	330	660
3100-25-6	ft	90	90	90						90 LB	in	11	6	20	21	25	17	26 1/2	14	27
	m	27	27	27						41 KG	mm	279	152	508	533	635	432	673	356	686
3101-19-4	ft			30	25	15				90 LB	in	9	4	11 1/4	21	19	15 1/2	22 1/2	13	25
	m			9	8	5				41 KG	mm	229	102	286	533	483	394	572	330	635
3101-23-4	ft			60	40	25				93 LB	in	9	4	11 1/4	21	23	15 1/2	24 1/2	13	26
	m			18	12	8				42 KG	mm	229	102	286	533	584	394	622	330	660
3101-23-6	ft			100	65	60				95 LB	in	11	6	11 1/4	21	23	17 1/2	24 1/2	13	26
	m			30	20	18				43 KG	mm	279	152	286	533	584	445	622	330	660
3101-23-8	ft			100	65	60				97 LB	in	13	8	11 1/4	21	23	19 1/2	24 1/2	13	26
	m			30	20	18				44 KG	mm	330	203	286	533	584	495	622	330	660
4830-31-5X	ft			75	75	65				122 LB	in	10 1/2	5 1/2	15	30	31	17	33	17 1/2	34 1/2
	m			23	23	20				55 KG	mm	267	140	381	762	787	432	838	432	876
4830-31-8	ft			80	80	90				125 LB	in	13	8	15	30	31	19 1/2	33	17 1/2	34 1/2
	m			24	24	27				57 KG	mm	330	203	381	762	787	495	838	432	876
4830-31-10	ft			*90	*100	100				128 LB	in	15	10	*15	30	31	21 1/2	33	17 1/2	34 1/2
	m			*27	*30	30				58 KG	mm	381	254	*381	762	787	546	838	432	876
4800-31-6	ft					70	50	40		122 LB	in	11 1/4	6	11 1/4	30	31	17	33	17 1/2	34 1/2
	m					21	15	12		55 KG	mm	286	152	286	762	787	432	838	432	876
4800-31-8	ft					75	75	50		125 LB	in	13 1/4	8	11 1/4	30	31	19	33	17 1/2	34 1/2
	m					23	23	15		57 KG	mm	337	203	286	762	787	483	838	432	876

SERIES 80000 / SERIES 3100 & 4800

USA: 800-444-3134 Europe: +44 (0) 1536 406999

Canada: 800-268-1756 Asia: 63-45-599-3721

www.reelcraft.com



Wind Things Up With Reelcraft